



# Cambridge O Level

---

## PHYSICS

5054/32

Paper 3 Practical Test

May/June 2022

### CONFIDENTIAL INSTRUCTIONS

**This document gives details of how to prepare for and administer the practical exam.**

**The information in this document and the identity of any materials supplied by Cambridge International are confidential and must NOT reach candidates either directly or indirectly.**

**The supervisor must complete the report at the end of this document and return it with the scripts.**

---

### INSTRUCTIONS

- If you have any queries regarding these confidential instructions, contact Cambridge International stating the centre number, the syllabus and component number and the nature of the query.  
email [info@cambridgeinternational.org](mailto:info@cambridgeinternational.org)  
phone +44 1223 553554

---

This document has **12** pages. Any blank pages are indicated.

## General information about practical exams

Centres must follow the guidance on science practical exams given in the *Cambridge Handbook*.

### Safety

Supervisors must follow national and local regulations relating to safety and first aid.

Only those procedures described in the question paper should be attempted.

Supervisors must inform candidates that materials and apparatus used in the exam should be treated with caution. Suitable eye protection should be used where necessary.

The following hazard codes are used in these confidential instructions, where relevant:

<b>C</b>	corrosive	<b>MH</b>	moderate hazard
<b>HH</b>	health hazard	<b>T</b>	acutely toxic
<b>F</b>	flammable	<b>O</b>	oxidising
<b>N</b>	hazardous to the aquatic environment		

Hazard data sheets relating to substances used in this exam should be available from your chemical supplier.

### Before the exam

- The packets containing the question papers must **not** be opened before the exam.
- It is assumed that standard school laboratory facilities, as indicated in the *Guide to Planning Practical Science*, will be available.
- Spare materials and apparatus for the tasks set must be available for candidates, if required.

### During the exam

- It must be made clear to candidates at the start of the exam that they may request spare materials and apparatus for the tasks set.
- Where specified, the supervisor **must** perform the experiments and record the results as instructed. This must be done **out of sight** of the candidates, using the same materials and apparatus as the candidates.
- Any assistance provided to candidates must be recorded in the supervisor's report.
- If any materials or apparatus need to be replaced, for example, in the event of breakage or loss, this must be recorded in the supervisor's report.

### After the exam

- The supervisor must complete a report for each practical session held and each laboratory used.
- Each packet of scripts returned to Cambridge International must contain the following items:
  - the scripts of the candidates specified on the bar code label provided
  - the supervisor's results relevant to these candidates
  - the supervisor's reports relevant to these candidates
  - seating plans for each practical session, referring to each candidate by candidate number
  - the attendance register.

## Specific information for this practical exam

### Number of sets of apparatus

In addition to a few spare sets, the minimum number of sets of apparatus to be provided should be sufficient to enable candidates to spend 20 minutes with the apparatus for each of Questions 1, 2 and 3, and one hour with the apparatus for Question 4. The order in which candidates answer the questions will be determined by the supervisor. Candidates may spend one hour circulating around Questions 1, 2 and 3, followed by an hour on Question 4, or vice versa.

Candidates should be advised in advance that they may, if they wish, use wrist-watches with stop-watch facilities, providing that such wrist-watches afford the required precision.

### Question 1

#### Items to be supplied by the centre (per set of apparatus, unless otherwise specified):

- thermometer (see Note)
- small piece of adhesive putty (e.g. Blu-tack or Patafix)
- 30 cm ruler with mm divisions.

#### Note

A liquid-in-glass stirring thermometer of approximate length 300 mm is suitable. Any other length of thermometer is also suitable, provided the dimensions are recorded in the supervisor's results. All candidates should be provided with identical thermometers, if possible. If more than one type of thermometer is used, supervisor's results must be provided for each type.

If the thermometer has an end cap, this must be removed. Use a small piece of adhesive putty (e.g. Blu-tack or Patafix) to prevent the thermometer from rolling off the bench.

A mercury-filled thermometer is not suitable as the consequence of a breakage may result in too much disruption to the exam.

#### Action at changeover

The supervisor should ensure that the thermometer is placed on the adhesive putty to prevent it from rolling off the bench.

#### Information required by examiners

Sample set of numerical results, clearly marked 'supervisor's results', obtained out of sight of the candidates.

## Question 2

Items to be supplied by the centre (per set of apparatus, unless otherwise specified):

- pendulum constructed from strong thread (string) and bob (see Note 1)
- two stands, two bosses and two clamps (see Note 2)
- heavy weight
- stop-watch
- metre rule
- set square
- split cork.

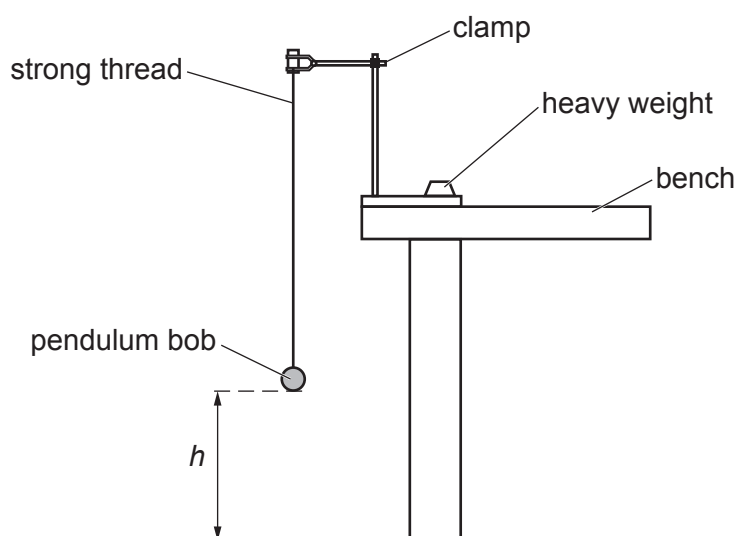

Fig. 2.1

## Notes

1. The pendulum thread must pass through a split cork at one end and be attached to a pendulum bob at the other. The pendulum bob could be any suitable object that keeps the strong thread straight and doesn't cause the stand to topple over e.g. a 100 g mass or a piece of adhesive putty. The thread length must be adjusted until the length from the bottom of the split cork to the centre of the pendulum bob is approximately 80 cm. The jaws of the clamp must then be tightened around the split cork to prevent the length of the pendulum from changing.

The position of the clamp on the stand must then be adjusted so that the height  $h$  of the **bottom** of the pendulum bob above the floor is  $50 \text{ cm} \pm 1 \text{ cm}$ .

2. One stand, boss and clamp will be used to attach the pendulum as shown in Fig. 2.1. A heavy weight must be placed on the base to prevent it from toppling. A second stand, with the boss and clamp attached, must be placed on the bench with the set square and the metre rule.

**Action at changeover**

The supervisor must ensure that the apparatus is as shown in Fig. 2.1, and that the second stand has the boss and clamp attached and is placed on the bench with the set square and metre rule.

**Information required by examiners**

Sample set of numerical results, clearly marked 'supervisor's results', obtained out of sight of the candidates.

### Question 3

Items to be supplied by the centre (per set of apparatus, unless otherwise specified):

- power supply (see Note 1)
- switch or plug key
- light-emitting diode (see Note 2)
- light-dependent resistor (see Note 3)
- small piece of adhesive putty (e.g. Blu-tack or Patafix)
- resistor of resistance  $100\ \Omega$
- resistor of resistance  $220\ \Omega$
- voltmeter capable of measuring a potential difference of up to  $5.0\text{V}$  to a precision of  $0.1\text{V}$  or better. An analogue or digital meter is suitable.
- connecting leads and crocodile clips (see Note 4)
- 30 cm ruler.

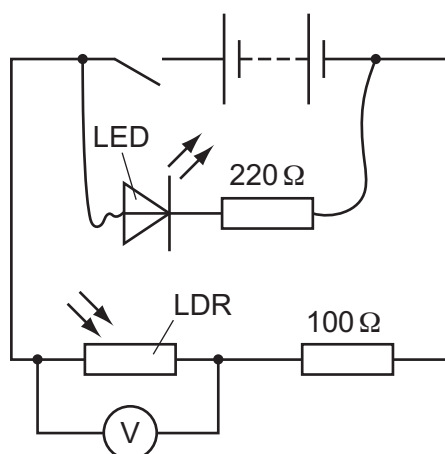

Fig. 3.1

### Notes

1. The following are suitable power sources:
  - three  $1.5\text{V}$  dry cells in suitable holders connected in series
  - four  $1.2\text{V}$  rechargeable cells in suitable holders connected in series
  - d.c. power supply of  $4.5\text{V}$ . Where candidates are provided with a power supply with a variable output p.d., the p.d. must be set by the supervisor and fixed (e.g. taped).
2. A suitable LED is the Kingbright L-793SRD-D 8 mm Super Bright Red LED 400 mcd. The RS Components stock number is 229-2368. The LED must be connected to long leads so that it can be moved.

3. A suitable LDR is the Silonex NORPS-12. The rapidonline.com catalogue number is 58-0132. A small piece of adhesive putty should be used to fix the LDR flat to the bench with the light sensitive surface uppermost.
4. The supervisor should set up the apparatus as shown in Fig. 3.1.

### **Action at changeover**

The supervisor must ensure that the circuit is in the configuration shown in Fig. 3.1. The LDR and the LED must be separated. If cells are used, they should be checked and replaced, if necessary.

### **Information required by examiners**

Sample set of numerical results, clearly marked 'supervisor's results', obtained out of sight of the candidates. The supervisor's measurements must be taken in the same lighting conditions as the candidates'.

### Question 4

Items to be supplied by the centre (per set of apparatus, unless otherwise specified):

- converging lens with a focal length of approximately 15 cm (see Note 1)
- illuminated cross-wire object (see Notes 2 and 5)
- light source (see Note 3)
- screen (see Notes 4 and 5)
- slotted masses (see Note 1)
- piece of adhesive putty (e.g. Blu-tack or Patafix)
- metre rule fixed to the bench with adhesive putty
- 30 cm ruler.

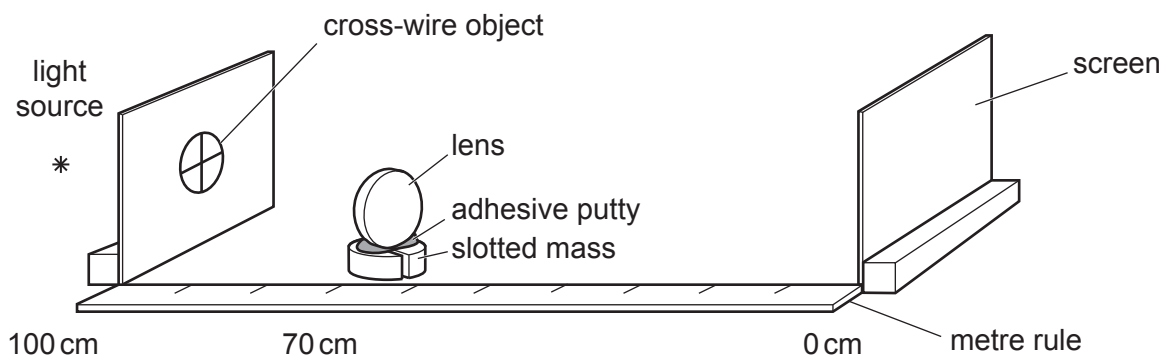

Fig. 4.1

### Notes

1. The lens must be mounted on one of the slotted masses using a small piece of adhesive putty (e.g. Blu-tack or Patafix).

The screen must be placed by the 0 cm mark of the metre rule, and the cross-wire object placed by the 100 cm mark of the metre rule. The lens must be placed between the cross-wire object and the screen approximately 70 cm from the screen with the face of the lens at an angle to the metre rule, as shown in Fig. 4.1. A small amount of adhesive putty should be used to fix the cross-wire object and ruler in place to avoid movement during the experiment.

Additional slotted masses must be placed on the bench next to the lens for the candidate to use. The number of masses should be sufficient for the candidate to raise the height of the lens to ensure that an image of the cross-wire object can be seen on the screen.

2. The cross-wire object should be made using a 20 cm × 20 cm square piece of stiff card or board. A hole of diameter 2.0 cm should be made in the card. The centre of the hole must be approximately 5 cm above the bench. Two small pieces of thin wire should be glued to the front of the card so that they cross the hole along two perpendicular diameters. Tracing paper should be attached to the back of the card to cover the hole.



3. The light source must be placed just behind the cross-wire object, as shown in Fig. 4.1, and lined up with the centre of the hole. The light must have sufficient brightness to illuminate the screen 100 cm away. A 12 V lamp, such as one found in a ray box, connected to a suitable power supply, is appropriate. The experiment must be performed in a darkened part of the laboratory.
4. The screen must have a white surface and should be made from a 20 cm × 20 cm square piece of stiff card or board.
5. The object and the screen should be supported so that they can stand perpendicular to the bench. This could be done by attaching wooden blocks to the base of the object and screen, as shown in Fig. 4.2. It must be possible for the candidate to move the position of the screen.



Fig. 4.2

### Action at changeover

The supervisor must ensure that the apparatus is in the configuration shown in Fig. 4.1 and as described in Note 1 with the light source switched off.

### Information required by examiners

Sample set of numerical results, clearly marked 'supervisor's results', obtained out of sight of the candidates.

**BLANK PAGE**

---

Permission to reproduce items where third-party owned material protected by copyright is included has been sought and cleared where possible. Every reasonable effort has been made by the publisher (UCLES) to trace copyright holders, but if any items requiring clearance have unwittingly been included, the publisher will be pleased to make amends at the earliest possible opportunity.

To avoid the issue of disclosure of answer-related information to candidates, all copyright acknowledgements are reproduced online in the Cambridge Assessment International Education Copyright Acknowledgements Booklet. This is produced for each series of examinations and is freely available to download at [www.cambridgeinternational.org](http://www.cambridgeinternational.org) after the live examination series.

Cambridge Assessment International Education is part of Cambridge Assessment. Cambridge Assessment is the brand name of the University of Cambridge Local Examinations Syndicate (UCLES), which is a department of the University of Cambridge.

**Supervisor's report**

Syllabus and component number

				/		
--	--	--	--	---	--	--

Centre number

--	--	--	--	--

Centre name .....

Time of the practical session .....

Laboratory name/number .....

**Give details of any difficulties experienced by the centre or by candidates (include the relevant candidate names and candidate numbers).**

You must include:

- any difficulties experienced by the centre in the preparation of materials
- any difficulties experienced by candidates, e.g. due to faulty materials or apparatus
- any specific assistance given to candidates.

Space for supervisor to record results, if relevant, e.g. temperature of the laboratory; results for Question 1.

### Declaration

- 1 Each packet that I am returning to Cambridge International contains all of the following items:
  - the scripts of the candidates specified on the bar code label provided
  - the supervisor's results relevant to these candidates
  - the supervisor's reports relevant to these candidates
  - seating plans for each practical session, referring to each candidate by candidate number
  - the attendance register.
- 2 Where the practical exam has taken place in more than one practical session, I have clearly labelled the supervisor's results, supervisor's reports and seating plans with the time and laboratory name/number for each practical session.
- 3 I have included details of difficulties relating to each practical session experienced by the centre or by candidates.
- 4 I have reported any other adverse circumstances affecting candidates, e.g. illness, bereavement or temporary injury, directly to Cambridge International on a *special consideration form*.

Signed ..... (supervisor)

Name (in block capitals) .....