



Cambridge International AS & A Level

CANDIDATE
NAME

--

CENTRE
NUMBER

--	--	--	--	--

CANDIDATE
NUMBER

--	--	--	--



COMPUTER SCIENCE

9618/33

Paper 3 Advanced Theory

May/June 2023

1 hour 30 minutes

You must answer on the question paper.

No additional materials are needed.

INSTRUCTIONS

- Answer **all** questions.
- Use a black or dark blue pen.
- Write your name, centre number and candidate number in the boxes at the top of the page.
- Write your answer to each question in the space provided.
- Do **not** use an erasable pen or correction fluid.
- Do **not** write on any bar codes.
- You may use an HB pencil for any diagrams, graphs or rough working.
- Calculators must **not** be used in this paper.

INFORMATION

- The total mark for this paper is 75.
- The number of marks for each question or part question is shown in brackets [].
- No marks will be awarded for using brand names of software packages or hardware.

This document has **12** pages.

1 Numbers are stored in two different computer systems by using floating-point representation.

System 1 uses:

- 10 bits for the mantissa
- 6 bits for the exponent
- two's complement form for both the mantissa and the exponent.

System 2 uses:

- 8 bits for the mantissa
- 8 bits for the exponent
- two's complement form for both the mantissa and the exponent.

(a) Calculate the normalised floating-point representation of 113.75 **and** show how it would be represented in each of these two systems.

Show your working.

System 1

Mantissa	Exponent																		
<table style="width: 100%; border-collapse: collapse;"> <tr> <td style="width: 20px; height: 20px;"></td> <td style="width: 20px; height: 20px;"></td> <td style="width: 20px; height: 20px;"></td> <td style="width: 20px; height: 20px;"></td> <td style="width: 20px; height: 20px;"></td> <td style="width: 20px; height: 20px;"></td> <td style="width: 20px; height: 20px;"></td> <td style="width: 20px; height: 20px;"></td> <td style="width: 20px; height: 20px;"></td> <td style="width: 20px; height: 20px;"></td> </tr> </table>											<table style="width: 100%; border-collapse: collapse;"> <tr> <td style="width: 20px; height: 20px;"></td> <td style="width: 20px; height: 20px;"></td> <td style="width: 20px; height: 20px;"></td> <td style="width: 20px; height: 20px;"></td> <td style="width: 20px; height: 20px;"></td> <td style="width: 20px; height: 20px;"></td> <td style="width: 20px; height: 20px;"></td> <td style="width: 20px; height: 20px;"></td> </tr> </table>								

System 2

Mantissa	Exponent																
<table style="width: 100%; border-collapse: collapse;"> <tr> <td style="width: 20px; height: 20px;"></td> <td style="width: 20px; height: 20px;"></td> <td style="width: 20px; height: 20px;"></td> <td style="width: 20px; height: 20px;"></td> <td style="width: 20px; height: 20px;"></td> <td style="width: 20px; height: 20px;"></td> <td style="width: 20px; height: 20px;"></td> <td style="width: 20px; height: 20px;"></td> </tr> </table>									<table style="width: 100%; border-collapse: collapse;"> <tr> <td style="width: 20px; height: 20px;"></td> <td style="width: 20px; height: 20px;"></td> <td style="width: 20px; height: 20px;"></td> <td style="width: 20px; height: 20px;"></td> <td style="width: 20px; height: 20px;"></td> <td style="width: 20px; height: 20px;"></td> <td style="width: 20px; height: 20px;"></td> <td style="width: 20px; height: 20px;"></td> </tr> </table>								

Working

.....

.....

.....

.....

.....

.....

[4]

(b) Explain the problem that occurred in **part (a)** when representing the number in **system 2**.

.....

.....

.....

..... [2]

2 (a) Draw **one** line from each machine learning category to its **most appropriate** description.

Machine learning category

Description

Supervised learning	simulates the data-processing capabilities of the human brain to make decisions
Reinforcement learning	enables learning by mapping an input to an output based on example input-output pairs
Deep learning	enables information related to errors produced by the neural network to be transmitted
Unsupervised learning	enables learning in an interactive environment by trial and error using its own experiences
	enables learning by allowing the process to discover patterns on its own that were previously undetected

[4]

(b) Describe the purpose of both the A* algorithm and Dijkstra's algorithm.

.....

.....

.....

..... [2]

- 3 (a) A hashing algorithm is used to calculate storage locations for records in a random access file. It calculates hash values by using the function modulus 3.

The function modulus gives the remainder after integer division.

For example, $1030 \text{ modulus } 3 = 1$. Therefore, the record key 1030 gives a hash value of 1.

Complete the table to show the remaining hash values.

Record key	Hash value
1030	1
1050	
1025	

[2]

- (b) Describe what happens, in relation to the storage or retrieval of a record in the file, when the calculated hash value is a duplicate of a previously calculated hash value for a different record key.

.....

.....

.....

.....

.....

.....

.....

.....

.....

.....

..... [4]

4 Two descriptions of user-defined data types are given.

Give appropriate type declaration statements for each, including appropriate names.

(a) A data type to hold a set of prime numbers below 20. These prime numbers are:

2, 3, 5, 7, 11, 13, 17, 19

.....
.....
.....
..... [2]

(b) A data type to point to a day in the week, for example Monday.

.....
.....
.....
..... [2]

5 (a) State, with a reason, where it would be appropriate to use circuit switching.

.....
.....
.....
..... [2]

(b) Give **two** benefits and **two** drawbacks of circuit switching.

Benefit 1

.....

Benefit 2

.....

Drawback 1

.....

Drawback 2

..... [4]

6 Several syntax diagrams are shown.

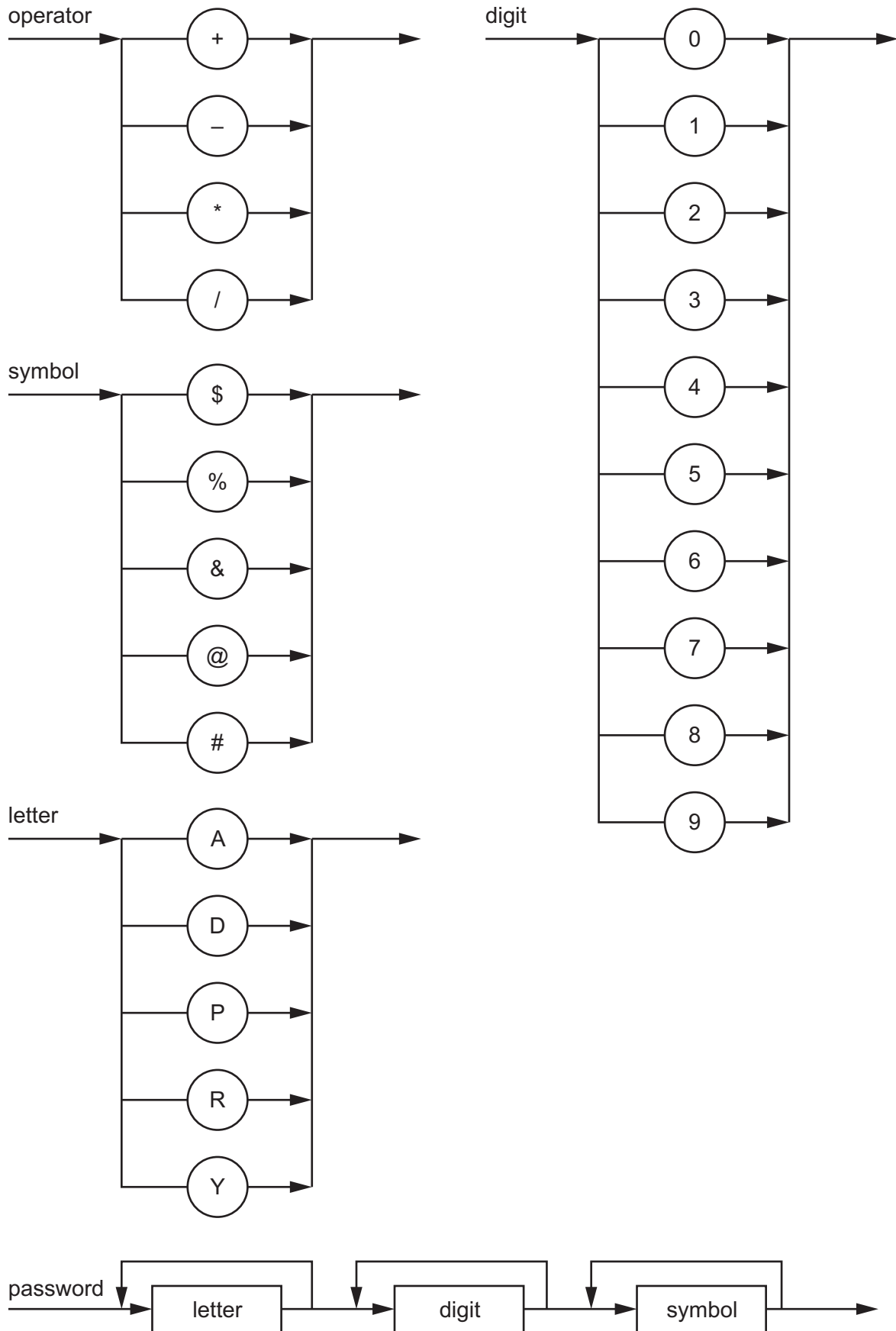

(a) State whether each of the following passwords is valid or invalid and give a reason for your choice.

DPAD99\$

Reason

.....

DAD#95

Reason

.....

ADY123?

Reason

.....

[3]

(b) Complete the Backus-Naur Form (BNF) for the syntax diagrams shown.

<symbol> ::=

.....

<letter> ::=

.....

[1]

(c) An identifier begins with one or more letters, followed by zero digits or one digit or more digits.

Valid letters and digits are shown in the syntax diagrams on page 6.

Draw a syntax diagram for an identifier.

[4]

- 7 (a) Complete the Karnaugh map (K-map) for the following Boolean expression.

$$Z = \bar{A}\bar{B}\bar{C}\bar{D} + \bar{A}\bar{B}\bar{C}D + \bar{A}B\bar{C}\bar{D} + \bar{A}B\bar{C}D + A\bar{B}\bar{C}\bar{D} + A\bar{B}\bar{C}D$$

		AB			
		00	01	11	10
CD	00				
	01				
	11				
	10				

[2]

- (b) Draw loop(s) around appropriate group(s) in the K-map to produce an optimal sum-of-products. [2]
- (c) Write the Boolean logic expression from your answer to **part (b)** as a simplified sum-of-products.

Z =

..... [2]

- (d) Use Boolean algebra to give your answer to **part (c)** in its simplest form.

Z = [1]

8 Outline the characteristics of massively parallel computers.

.....

.....

.....

.....

.....

..... [3]

9 (a) Encryption is used to alter data into a form that makes it meaningless if intercepted.

Describe the purpose of asymmetric key cryptography.

.....

.....

.....

..... [2]

(b) Identify **two** benefits and **two** drawbacks of quantum cryptography.

Benefit 1

.....

Benefit 2

.....

Drawback 1

.....

Drawback 2

..... [4]

- 10 The pseudocode algorithm shown copies an active accounts text file `ActiveFile.txt` to an archive accounts text file `ArchiveFile.txt`, one line at a time. Any blank lines found in the active accounts text file are replaced with the words "Account not present" in the archive accounts text file.

Complete this file-handling pseudocode.

```

DECLARE Account : STRING
.....

OPENFILE "ArchiveFile.txt" FOR WRITE

WHILE NOT .....
    READFILE "ActiveFile.txt", Account
    IF Account = "" THEN

        WRITEFILE "ArchiveFile.txt", " ....."
    ELSE

        WRITEFILE "ArchiveFile.txt", .....
    ENDIF
ENDWHILE

.....
CLOSEFILE "ArchiveFile.txt"
    
```

[5]

- 11 Pseudocode is to be written to implement a queue Abstract Data Type (ADT) with items of the string data type. This will be implemented using the information in the table.

Identifier	Data type	Description
FrontPointer	INTEGER	points to the start of the queue
RearPointer	INTEGER	points to the end of the queue
Length	INTEGER	the current size of the queue
Queue	STRING	1D array to implement the queue

A constant, with identifier `MaxSize`, limits the size of the queue to 60 items.

- (a) Write the pseudocode to declare `MaxSize`, `FrontPointer`, `RearPointer`, `Length` and `Queue`.

.....

.....

.....

.....

.....

.....

.....

.....

[3]

- (b) Complete the following pseudocode for the function `Dequeue` to remove the front item from the queue.

```
FUNCTION Dequeue RETURNS STRING
  DECLARE Item : STRING

  ..... > 0 THEN

    Item ← .....

    .....
    IF Length = 0 THEN
      CALL Initialise // reset the pointers
    ELSE
      IF FrontPointer > MaxSize THEN

        ..... ← 1
      ENDIF
    ENDIF
  ELSE
    OUTPUT "The print queue was empty - error!"
    Item ← ""
  ENDIF
  RETURN Item
ENDFUNCTION
```

[4]

- (c) Explain how a new element can be added to the queue if it is implemented using two stacks.

.....

.....

.....

.....

.....

.....

..... [4]

- 12 (a) Describe what is meant by recursion.

.....

.....

.....

..... [2]

- (b) A Fibonacci sequence is a series of numbers formed by adding together the two preceding numbers, for example:

0, 1, 1, 2, ...

This function calculates and returns values in the Fibonacci sequence and uses recursion.

```

FUNCTION Fib(Number : INTEGER) RETURNS INTEGER
  IF Number <= 1 THEN
    Result ← Number
  ELSE
    Result ← Fib(Number - 1) + Fib(Number - 2)
  ENDIF
  RETURN Result
ENDFUNCTION
    
```

Complete the trace table for the function when it is called as Fib(5).

Call number	Function call	Number	Result	Return value
		5		

[5]

Permission to reproduce items where third-party owned material protected by copyright is included has been sought and cleared where possible. Every reasonable effort has been made by the publisher (UCLES) to trace copyright holders, but if any items requiring clearance have unwittingly been included, the publisher will be pleased to make amends at the earliest possible opportunity.

To avoid the issue of disclosure of answer-related information to candidates, all copyright acknowledgements are reproduced online in the Cambridge Assessment International Education Copyright Acknowledgements Booklet. This is produced for each series of examinations and is freely available to download at www.cambridgeinternational.org after the live examination series.

Cambridge Assessment International Education is part of Cambridge Assessment. Cambridge Assessment is the brand name of the University of Cambridge Local Examinations Syndicate (UCLES), which is a department of the University of Cambridge.