



**Cambridge Assessment**  
International Education

Teacher Guide – Paper 2  
Incorporating language learning support  
**Cambridge IGCSE™**  
**Pakistan Studies 0448**

For examination from 2020

Copyright © UCLES 2019 (updated Nov 2021)

Cambridge Assessment International Education is part of the Cambridge Assessment Group. Cambridge Assessment is the brand name of the University of Cambridge Local Examinations Syndicate (UCLES), which itself is a department of the University of Cambridge.

UCLES retains the copyright on all its publications. Registered Centres are permitted to copy material from this booklet for their own internal use. However, we cannot give permission to Centres to photocopy any material that is acknowledged to a third party, even for internal use within a Centre.

---

# Contents

---

Introduction .....	4
Getting started .....	5
1: Planning the course .....	6
2: Planning lessons.....	9
3: Classroom practice .....	14
4: Preparing learners for final assessment .....	20
5: Resources and support.....	25
Appendix: Sample lesson plan template .....	26

## Introduction

---

### The purpose of the teacher guide

This teacher guide is designed to help you to organise and plan your teaching for Cambridge IGCSE Pakistan Studies. It also offers advice and guidance on teaching strategies and how to prepare your learners for the final assessment.

As an international awarding body, many of our candidates are either multi-lingual or possess English as a second language which presents them with great opportunities but also with potential barriers. Learners cannot develop academic knowledge and skills without access to the language in which they are discussed, constructed and evaluated.



In this guide we have also included some prompts and tips on how to incorporate the development of language skills within the general teaching of this subject. This information is indicated in the text with the icon shown here.

Where language levels are already highly developed amongst learners, this advice will not be applicable. However, it is often the case that those learners with lower ability skills in general and those with lower ability language skills tend to share similar misunderstandings.

---

## Getting started

---

### School Support Hub

You should make sure at an early stage that you have access to the School Support Hub, [www.cambridgeinternational.org/support](http://www.cambridgeinternational.org/support). You can obtain a login from your Examinations Officer.

The School Support Hub provides a wide range of resources to help you, including:

- syllabuses
- past examination papers and specimen papers
- mark schemes
- examiner reports (after first sitting)
- example candidate response booklets (after first sitting)
- schemes of work
- a resources list
- community resources and discussion forum

All of these forms of teacher support are invaluable in helping you and your learners understand exactly what Cambridge expects of candidates in examinations, and will help you to prepare your learners appropriately.

### Syllabus

When planning your course, your starting point should be the syllabus. This contains information not only on the curriculum content but also the overall aims and assessment objectives. It gives details of the papers, the grade descriptions and additional information (such as the minimum marks needed for particular grades). It is most important that you become thoroughly familiar with all parts of the syllabus document.

### Scheme of work

You will then need to devise a scheme of work. To do this, you need to think how you will organise the time that you have available to help learners to understand and learn all of the facts and concepts required by the syllabus, and to develop the necessary skills. Cambridge International provides a scheme of work that you could use as a starting point but you will undoubtedly want to produce your own at some point. Your scheme of work will help you to determine what resources you will require to deliver the course and this will help you to build up teaching, learning and reference resources such as text books and worksheets.

## 1: Planning the course

---

This section looks at how you can plan your course to ensure that you can cover the whole syllabus within the time that you have available. It includes long-term planning (developing a scheme of work) and planning for individual lessons. It also includes ideas and support for incorporating language into the lesson to help learners become more fluent and accurate users of English.



Language is an important part of communication and the aim of considering this within a lesson is to expose learners to situations where they need to use English to complete the tasks given. The language focus is not an additional element to be added to the course but should be seen only as the medium through which the topic (content) is taught.

The promotion of critical thinking skills and collaborative work is considered to be very important in acquiring language and improving fluency whatever the topic. Personalisation of the topic is also known to increase motivation and self-confidence as well as interest in the topic.

Section 4 provides some ideas and activities for incorporating language into the lesson without increasing the teacher's workload.

### 1.1 Key factors to consider when planning your course

These factors will need to be considered before starting the planning of your course.

- the amount of teaching time available each week for the duration of the course
- the availability of resources such as text books, computers, atlases etc.
- the previous learning of your learners
- the level of English language of the learners
- whether your group is mono- or multi-lingual
- whether your teaching groups will be mixed ability or will be streamed by ability
- the number of lessons you will need to cover the syllabus (the recommended time for a Cambridge IGCSE course is 130 hours of teaching time)
- the school calendar; holidays, examinations, etc.

### 1.2 Long-term planning

A long-term plan will provide the overall structure of your course. It will include the order in which topics will be taught, the approximate length of time to be spent on each and the factors listed in Section 1.1 above. It will need to take into account the number and nature of the groups following the course and whether they should all follow the same path through the course. There may, for example, be issues with the use of computers or text books if two groups are studying a topic at the same time. In this case it would be better if the plan was organised so that groups could study such a topic at different times.

Topics should also, ideally, be arranged so that they fit into the school's sessions, so that a topic is not split because of a school holiday or an examination session.

In a two year course the second year will probably have fewer weeks because of the timing of the Cambridge International examinations.

It is important to note that you do not need to teach the syllabus content in the order in which it is printed in the syllabus. It is likely that you will want to order your teaching to suit your particular needs and preferences. This may be done in a number of ways.

- Start your course with Section 1 (Location of Pakistan) and Section 6 (Trade), perhaps because you can see ways of linking the learning objectives in these two areas together. It links to investigating transport, to the study of Pakistan's trading partners or to a visit to a dry port or port.
- Start with a course in practical techniques such as map work and Pakistan's place in the world to generate enthusiasm.

- Start with topics which are conceptually easier, saving the more difficult topics for the second year of the course.
- Use the suggested pattern in the 'Schemes of Work' provided on the School Support Hub.
- Follow your own and learners' interests and enthusiasms to begin with.

Long-term planning will also consider what you would like the learners to be able to communicate either in spoken or written form at the end of the course. This will help with identifying what language could be included in medium- and short-term plans.

A long-term plan should also consider how cartographic and graphical skills will be developed and which topics will contribute largely to the development of these skills.

A long-term plan is not 'set in stone'; it is a working document. As the course progresses you can adapt it as required. When you have worked through it once or twice you will have a much better idea of the best way for you to work through the syllabus.

### 1.3 Medium-term planning

Medium-term planning is the most important of the three types. It defines, in some detail, what will be taught and when. It also describes how language skills, practical work and other activities are to be incorporated into the course. Medium-term plans are often called 'Schemes of Work' and can be shared at the whole school level to inform other Pakistan Studies teachers of your plans.

Some examples of schemes of work can be found on the School Support Hub ([www.cambridgeinternational.org/support](http://www.cambridgeinternational.org/support)). A password is needed to access the site and your Examination Officer will be able to provide you with one.

The Cambridge scheme of work is useful as:

- an example of **one way** of moving through the course
- a good source of possible activities mapped to each part of the syllabus
- a good source of exercises and resources.

Generally, we recommend that you only use this as a reference to help you create your *own* scheme of work because, it:

- represents only **one** possible approach and so is not necessarily the best for your learners
- does not take into account the ethos, approach and/or facilities of your centre
- is arranged in a way that might not fit in with your long-term plan
- has no statement of the amount of time required for each element.

When adapting an existing scheme of work:

- add timings for each section
- you could include a note about the sort of output you would like your learners to produce in terms of language, e.g. oral, written, group/pair work, discussions, etc.
- always check the URLs before using them with your learners; web addresses can change, and you also need to know that what you are accessing is appropriate for your learners.

A medium-term plan is best developed with contributions from all of the teachers who will be using it. If they have had an input they will feel an 'ownership' of the plan and will be more likely to adhere to it.

A medium-term plan should be flexible and updated when necessary. It should be amended if it is found not to be working as planned. It should be reviewed at the end of each school year to assess how well it has worked and to decide if any improvements could be incorporated.

## 1.4 Short-term planning

Short-term planning involves planning for a single lesson or perhaps a small group of lessons.

It should include the:

- content and the language of the lesson
- activities that will take place
- progress that is expected of the learners during the lesson.

Short-term planning is something that is done by an individual teacher, taking into account their own strengths and the needs of the learners they will be teaching. Teachers new to the subject may need guidance but the plan should still be their own.

This process is covered in more detail in the next section, *2 Planning lessons*.



---

## 2: Planning lessons

---

### 2.1 Lesson plans and templates

A lesson plan is written by the teacher and should include details of how the lesson is intended to proceed. It should take account of:

- what is to be taught (learning objectives)
- what is to be achieved by the learners (lesson objectives, content and language)
- what the learners already know (previous learning and relevant knowledge)
- how learners' understanding will be monitored (assessment of learning)
- how learners at different levels of ability are going to access the lesson (differentiation).

It should detail the learning activities which will take place and have approximate timings showing how long each part of the lesson will last. It should also note the language focus for the lesson in brief.

A lesson should ideally have three main parts:

- |                  |  |
|------------------|--|
| <b>beginning</b> | this should be an activity that engages and motivates the learners, as well as stimulating the background knowledge that the learners can bring to the topic |
| <b>middle</b>    | this should include the main learning and language activities of the lesson  |
| <b>end</b>       | this should be an activity/activities in which learners can assess their understanding of what has gone before and feedback on it.                           |

### 2.2 Constructing a lesson plan

It can be helpful to have a printed template to use in lesson planning. You can design your own, or there are many available on the internet or in books. On the following pages you will find an example of a completed lesson plan which includes helpful guidance.

A blank template of the example below is available in the Appendix for you to copy.

<b>Lesson:</b>		<b>School:</b>	
<b>Date:</b>		<b>Teacher name:</b>	
<b>Class:</b>	<b>Number present:</b>	<b>Number absent:</b>	
<b>Learning objectives to which this lesson is contributing</b>	This will be based on something written in your medium-term plan. It will state which part of the syllabus the lesson is going to address.		
<b>Lesson objectives</b>	These may be the same as the learning objectives but more often will be only a part of them. This is what you intend the learners to fully grasp by the end of the lesson. It should be a realistic target and many learning objectives will take more than one lesson to be fully understood. It should also include a reference to the language the learner is likely to need to be able to reach the targets you set.		
<b>Vocabulary, terminology and phrases</b>			
<b>Previous learning</b>			
<b>Plan</b>			
<b>Planned timings</b>	<b>Planned activities</b>	<b>Resources</b>	
Beginning	This should be a relatively brief part of the lesson and should 'switch the learners on' to Pakistan Studies, rather than what they were doing previously. It may be a short question and answer session, or a simple written task to assess what they know about the topic to be covered This starter session should also stimulate the interest of the learner by providing materials such as visuals for the particular vocabulary needed or some activity which is personalised to encourage the learners to bring their own background knowledge and interest to the topic. This should be learner focused with as little teacher talk time as possible. Give an estimated time, usually about five minutes.	Your plan should also include a list of the resources (books, internet, practical equipment, etc.) which will be needed in each session of the lesson.	



Middle

This may build on and extend previous understanding, explore and solve practical problems, develop knowledge and skills, practise previously learned techniques or any of many other alternatives. It is important not to include too many activities, but equally important not to spend so much time on one activity that learners become demotivated. Good lessons will involve the learners in the activities as much as possible. Activities should encourage the learners to have confidence in communication through speaking or writing and there should be some feedback from the teacher regarding possible language errors. Delayed feedback is recommended to avoid demotivating the learners and hindering communication. Timings should be included for each separate activity.



End

This part of the lesson brings it to an organised conclusion. Learners (in groups or pairs) can assess how well they understand the material covered during the lesson. This may involve a short written exercise or a question and answer session. This may also include feedback from the teacher on some language errors noticed during the lesson, for example, pronunciation of certain words, use of tenses. It may also be used to link to whatever is going to happen in the next session. This should again take around five minutes at most.

### Additional information

**Differentiation: How do you plan to give more support? How do you plan to challenge the more able learners?**

How will you try to ensure that the lesson is accessible to all of the learners so that all will benefit from the experience? This is especially important with mixed ability groups. There is more on differentiation in the next section.

**Assessment: How are you planning to check learners' learning?**

It is good practice to check:

- what your learners knew/understood before the lesson (content)
- how this has changed after the lesson, including language and communication improvements (language).

**Health and safety check: ICT links**

If your lesson includes any fieldwork or outdoor activity, an assessment of the risks involved should be included with the lesson plan.

**Reflection and evaluation**

**Reflection**

Were the lesson objectives realistic?

What did the learners learn today?

What was the learning atmosphere like?

Did my planned differentiation work well?

Did I stick to timings?

What changes did I make from my plan and why?

**Use the space below to reflect on your lesson. Answer the most relevant questions from the box on the left about your lesson.**

As soon as possible after the lesson you need to think about how well (or badly) it went. There are two reasons for this; if you share your plan with other teachers in your Centre it will enable them to learn from your experiences. It is a good idea to discuss with colleagues how well lessons went. This applies whether they went well or whether there were problems.

It will also help next time you teach the same topic. If the timing was wrong or the activities did not fully occupy the learners, you may want to change some aspects of the lesson next time.

There is no need to re-plan a successful lesson every year, but it is always good to learn from experience and to incorporate improvements next time.

**Summary evaluation**

**What two things went really well? (Consider both teaching and learning.)**

- 1.
- 2.

**What two things would have improved the lesson? (Consider both teaching and learning.)**

- 1.
- 2.

**What have I learned from this lesson about the class or individuals that will inform my next lesson?**

## 3: Classroom practice

The aim of any teacher is to get their learners to gain knowledge and understanding, to develop the skills to be able to apply this knowledge, and to learn to communicate what they know as effectively and accurately as possible in the time available to them on the course.

### 3.1 Active learning

Not every topic in Pakistan Studies can be taught by means of outdoor learning. A description/explanation by the teacher is easily forgotten by the learner, even if it was understood in the first place.

Videos of some environmental processes and computer animations can help, but they are still 'passive'. The learner is not involved in 'discovering' the information.

 Research has shown that the more a learner is involved in the process of learning, the more they retain. This is also true of language acquisition.

The learning pyramid below shows the percentage of information retained as a result of different forms of delivery stimulating different learning processes.

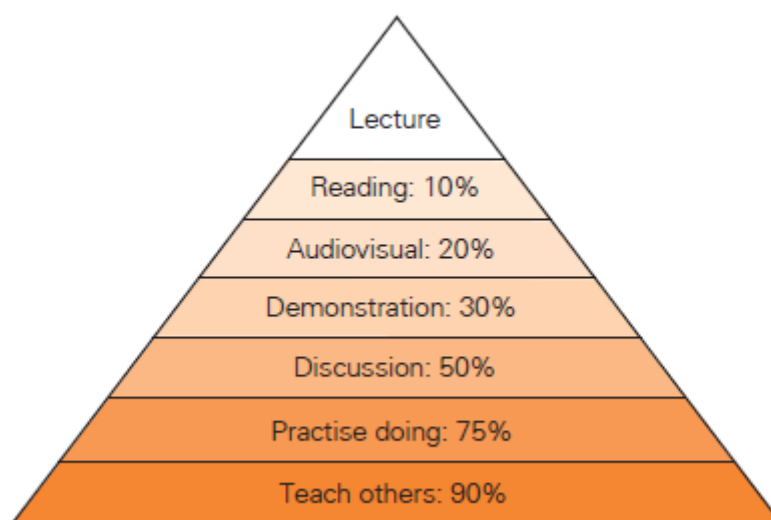

From this it will be seen that although audiovisual (videos and computer animations) may be better than a lecture (being told by a teacher), there are methods which are better still. Clearly not everything can be absorbed by discussion and practice, but activities where the learners actually participate work better.

 At least some such activities (active learning) should be used alongside field work, outdoor learning and discussions etc. in order to maximise learning. There will not be time for everything to be covered in this way but some topics certainly should be. If you give learners guiding questions to answer while listening this will activate knowledge and language and will allow the learners to feedback the answers or contribute to the group discussion more effectively. This is an example of what is called 'scaffolding'.

There are, of course, many other methods of getting learners involved and plenty of ideas in books and on the web.

## 3.2 Differentiating the activities

Differentiation is a way of trying to ensure that members of your group with differing abilities can all access the material you are delivering. There are a number of ways of approaching this problem and, again, they can be found in books and on the web. They fall into three main categories.

- **Differentiation by outcome** - In this method an open-ended task is set which can be accessed by all, e.g. 'Find out how low temperatures affect the lives of people in the mountainous regions'. Learners will produce different results according to their ability, but all of their 'outputs' will be valid.
- **Differentiation by task** - Learners are set slightly different tasks based on the same objective. This may involve worksheets which pose questions on the same topic where differing amounts of understanding are required.
- **Differentiation by support** - All learners undertake the same task but those who are weaker are given additional support. Writing frames, where a template is provided for them to record their work, are one way of doing this.

## 3.3 Integrating content and language in the course

In previous sections we have stressed that the objective of the language element of a lesson is to help the learners gain greater confidence in communicating their knowledge of the subject. Whether you are teaching a class including learners who have English as their second language, who are multi-lingual or who only speak English, the same difficulties of written expression occur within the subject to both lower level ability and second language learners.

Subject teachers are not expected to teach English, however, the language and terminology of a subject should be learned at the same time as the subject content, as a fluent part of the content, so that it has greater meaning and offers contextual understanding; subject-specific language should not be left to a specified language lesson. The confidence to communicate in accurate and precise language will also be of benefit to learners taking an external examination in English at the end of the course. A number of examination questions require explanations and learners can gain higher marks if the language is used accurately. For example, comments by some examiners on previous candidate scripts have noted the incorrect use and understanding of vocabulary, the lack of ability to write a logical explanation and answers that contain contradictions. It will also benefit learners in the long term, should they continue their studies in the subject at a higher level with a view to their careers.

The teacher's role should, therefore, also be to support the language element of the lesson that underpins the content. This element should enhance learners' communicative skills and their accurate use of the language. A key part of this should be for teachers and learners to notice the language used in different stages of the lesson.

Here are some strategies that you can try in your next lesson:

- record language prompts on the whiteboard
- encourage learners to underline key terms
- use images
- provide writing frames
- enable learners to write collaboratively
- introduce learners to new language before setting a task
- provide sentence stems and model language
- activate prior knowledge of the subject
- create a bank of useful expressions
- repeat explanations and progressively increase the difficulty of explanations
- provide feedback on language and content
- highlight examples of good language use from learners.

To help learners with their use of language it may also be helpful to consider the following questions when writing a lesson plan for a subject area:

- What is the topic and what does it cover? (content)
- Is there something in the topic you can make personal to the learners? For example, is there something you can relate to their particular culture to stimulate interest and prior knowledge. (context, personalisation)
- What language will your learners need to produce during the lesson and later in the exam? (English)
- What is the language focused on? For example, it may be to explain a result, justify a decision, describe a result, or interpret given information. You can also think about the relevant vocabulary and terms they could practise to help with precision.

### 3.3.1 Some ways to integrate content and language

Language is the medium through which the content is delivered and the main aim is not to teach the language but provide language support and use it in interesting ways. The following suggestions are provided to help you think about what might support learners with the language during the lesson:

- Use of visuals and charts for building vocabulary and understanding meaning – this has been shown to stimulate interest and the learners' prior knowledge.
- Use gap fill and word definition to discover meaning – this helps with retaining the language to a greater extent than when learners are simply given the answers.
- Use checking questions to ensure understanding – asking learners if they could tell the group or their partner what they have to do is an important part of communication and retention.
- Pair and group work is important – learners learn from each other and it has been shown that teenagers prefer to work in groups rather than on their own. Learners need a safe place to practise the language before expressing it individually.
- Personalise the topic – this increases motivation and assimilation of the language.
- Oral interaction between learners in English about the content is beneficial, as is cooperative work. The more the learners speak, the greater the development of accuracy and confidence in using the language.
- Repeat vocabulary, grammar and useful phrases commonly used in the topic. For example, practise using words to compare and contrast words to make a point or develop an argument.
- If learners are encouraged to notice the language they are more likely to use it at a later date.
- The use of context is important for learners to understand meaning.
- Language needs to be used in conversation before it can be assimilated as part of the output.

### 3.3.2 Possible activities

- (1) Starter – activate prior knowledge, use simple visual clues to vocabulary, match pictures to words.
- (2) Bring in everyday recognisable items which are related to the topic (realia).
- (3) Personalisation – start the lesson by making the topic relate to the learners' lives e.g. favourite food eaten every day.
- (4) Vary the font and sizes for reading exercises and use pictures or cartoons to explain concepts. Underlining key words or phrases helps the learner to notice the language.
- (5) Learners acquire and retain language through discovering the meaning themselves from within the text or through ordering a set of sentences to describe a process.
- (6) Repeat the key language during the lesson in different exercises, e.g. use of the passive tense in writing up the impacts of an event and when to use the definite and indefinite article (Exercise 1).
- (7) To help with developing thinking skills and using the language, start by asking simple questions using *what*, *when*, *where* and *which* followed by more challenging ones using *how* and *why*. This works well in group and pair work.
- (8) Have a glossary and word bank available. Give the learners specific words and phrases to build the precise and more complex sentences they will need to use in their reports.
- (9) Provide scaffolding – i.e. using activities where learners need to add correct answers from a choice to make the sentences correct. Follow this by freer practice of the same language used in the sentences.
- (10) Try and ensure pronunciation and word stress is correct. You can use delayed feedback, i.e. make notes during the group discussion time of difficult language areas and highlight this to the whole group at the end of the lesson.



### 3.3.3 Some examples of exercises to integrate language learning within lessons

#### Exercise 1: The use of the passive voice

One of the most common uses of the passive voice is in writing about impacts. Learners are likely to write about impacts in several topics during the two years of the course for example the impacts of extreme temperatures, flooding or drought and quite often they can draw from examples that have previously happened and so should be written in the past tense. Often teachers write the aim of a lesson on the board and provide an overview of whether students should refer to people, the environment or both. This helps with spelling and structuring the response. The impacts may then be discussed and are then left for the learners to write themselves.

If the learner is following a pre-determined plan or framework (scaffolding), this can make the task somewhat simpler.

When the learner comes to write up the impacts of something like a drought s/he should do it using the past passive voice as follows:

*The impacts of drought on agriculture and industry in Balochistan has meant that most of the livestock died due to there being no rainfall for the last three years. Crops failed which left many people starving and 9 children died in southern Sindh. Industry was affected too as there was a shortage of raw materials, such as cotton, which meant that exports were reduced and imports had to be increased.*

With guidance, most learners should be able to complete such an exercise recognising the difference between what has happened in the past compared to what might happen in the future thereby allowing them to apply the passive voice to other tasks correctly.

#### Exercise 2: Vocabulary and writing in sequence

Here is an example of how you might convert an existing past question into a cloze language learning exercise within your subject teaching. You could make the task even more challenging by adding alternative words to the list that are not needed to complete the passage but that students will need to think about more deeply.

Complete the following sentences about hydel power using words from the list below.

**highland      electricity      shadow      Gilgit      turbines      rainfall      climate**

Hydel power is \_\_\_\_\_ generated by using the fast flow of water to move \_\_\_\_\_ which drive generators. The \_\_\_\_\_ sometimes causes problems in developing hydel power in Pakistan. This is because some areas like \_\_\_\_\_ and Chitral have less rainfall and electricity cannot be generated if there is not enough water. Similarly, some areas lack rainfall because they are in a rain \_\_\_\_\_ area. Therefore dams tend to be located in \_\_\_\_\_ areas where there is more precipitation. Overall, \_\_\_\_\_ is not evenly spread throughout Pakistan which means that some places are not able to develop hydel power.

### **Exercise 3: Matching exercises**

In this example using a diagram to match labels with visuals can help contextualise a word or process and help define it against associated terms.

The diagram shows three of the processes involved in the spinning of cotton.

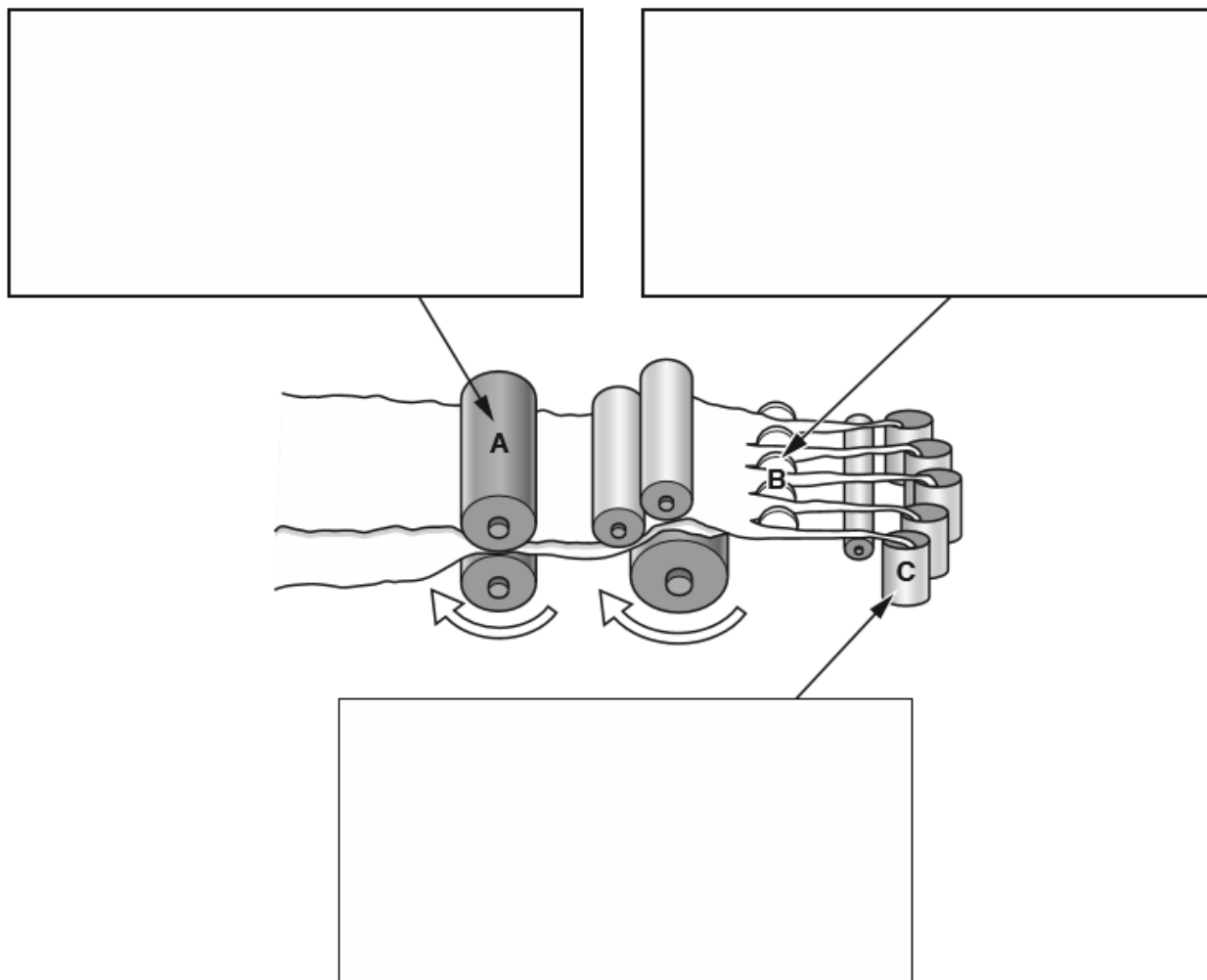

Match the processes to the corresponding letters on the diagram above:

- Rollers used to flatten cotton fibres/smooth out folds/straighten fibres
- Teasing wires produce loose bundles of fibre (slivers)/the fibres are divided into threads
- Fast and slow rollers divide slivers more/slivers stretched/pulled out further

**Exercise 4: Structured support**

Here's an example where learners have to think about the terms, the position they occupy on a diagram and the changes they represent over time whilst being able to interpret the different dimensions of the graph at the same time.

The graph shows population change over time.

- (i) Circle the correct term for the graph.

**Total Population Model**

**The Demographic Transition Model**

**The Natural Increase Model**

- (ii) Complete the label on the graph below labelled 'Z' choose the correct words from the list.

**natural increase**

**natural decrease**

**total population**

- (iii) At which stage is the population growing fastest? Circle the correct answer.

stage 1

stage 2

stage 3

stage 4

- (iv) State two reasons for the declining birth rate as shown in stage 3.

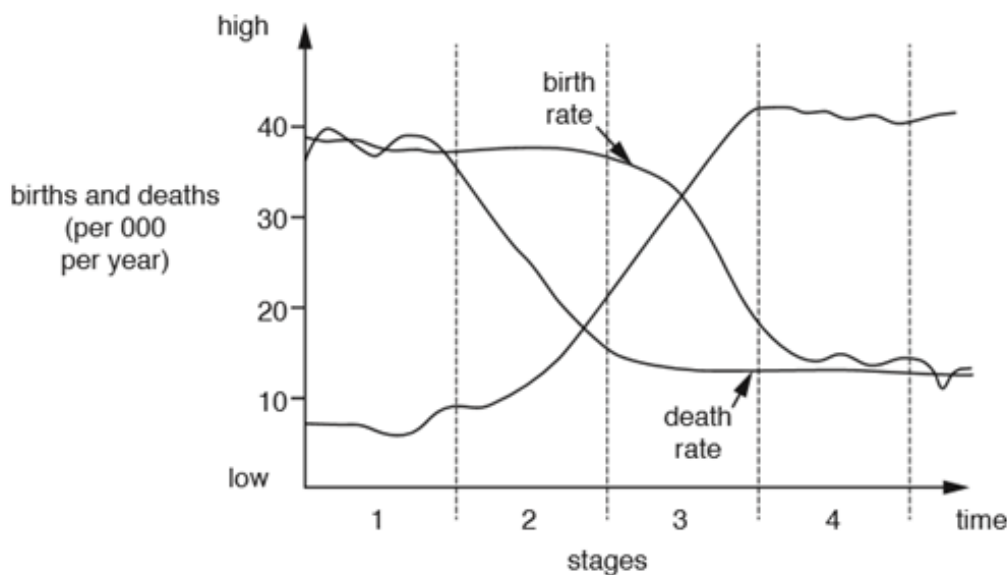

## 4 Preparing learners for final assessment

---

You will find past papers and mark schemes on the School Support Hub ([www.cambridgeinternational.org/support](http://www.cambridgeinternational.org/support)). These can be used by learners for exam practise and/or for formative assessment throughout the course or at the end of a topic. You will also find the Principal Examiner Reports for Teachers (PERT), which is produced after each examination series. The PERT indicates the strengths and weaknesses of candidate performance across the whole cohort and can be used to help you identify common areas of misconception, misunderstanding and weakness in order to improve your teaching.

### 4.1 Study habits

By the start of the Cambridge IGCSE course, the learner will probably have explored preferred methods for studying and revising. However, not all of these methods are necessarily effective for all learners.

Much research has been published on this subject, suggesting that some of the following methods are not effective:

- generous use of highlighters
- reading and re-reading notes
- working exhaustively and alone
- re-writing existing notes to create a more attractive set of notes.

Dedicated learners will often revise intensely for long periods and convince themselves that they have prepared thoroughly. Sadly, they may well have been largely wasting their time, especially if they are aiming to develop a deep and lasting understanding of the topic. In addition to just passing the examination.

Here are some methods that are proven to work for most learners:

- Distributive practice: that is, spreading out study over time. This method is believed to aid true understanding of the topics.
- Studying in short bursts, followed by testing themselves regularly over several weeks.
- At the end of a revision session, writing down what they can remember.
- Creating a revision timetable for the mock and final exams. This will ensure that they study different subjects little, but often.
- Answering many practice questions/past papers.
- Connecting ideas together by the use of mind maps.
- Using revision guides rather than the subject textbook.

Encourage your learners to consider and develop what works best for them.

## 4.2 Deep subject understanding

When learners start to make connections between topics, the study of the subject becomes more enjoyable and they gain a deeper understanding of what they are doing.

Concept maps (mind maps) can be drawn and connections made between sub-topics in a unit, between units in a syllabus, and indeed between related subjects.

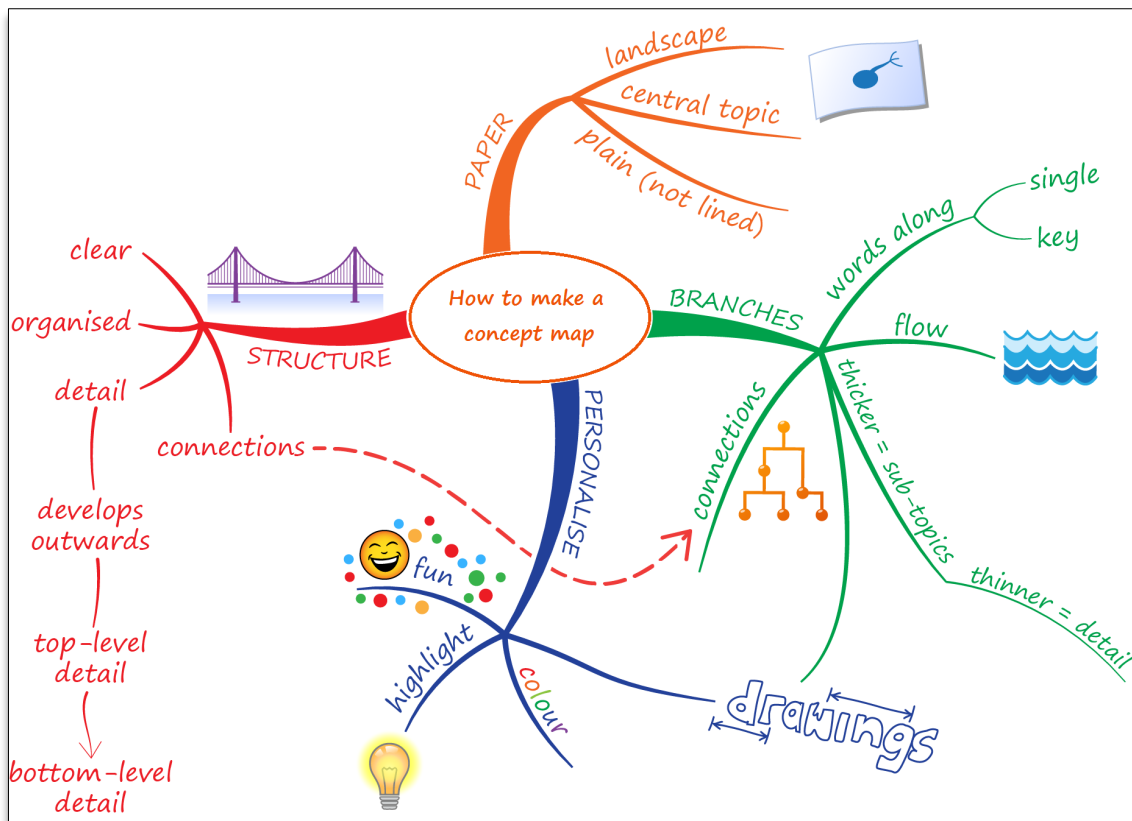

## 4.3 Technology in and out of the classroom

There are a great range of technological tools available for use inside and outside of the classroom. It is important for learners to experience their learning in a variety of different ways, not least to maintain interest and motivation. Below are just some of the possibilities.

### 4.3.1 Virtual field work

This is especially useful for illustrating locations in Pakistan to learners, for example when teaching about the Northern areas to learners in Sindh or vice versa. Those different environments may be worlds apart from the experience of the local learners and visiting all the locations studied is not possible. Learners can see the locations for themselves and interrogate the surroundings and compare it to their own experiences. Since these tools are interactive, they are much better than just reading and memorising the topic. Using Google Earth and Google images, students and teachers can create their own virtual field trips that will bring the learning to life. All that is required is internet access and it is free to download Google Earth.

### 4.3.2 Mobile apps

Mobile apps for education have to be carefully selected to make sure they provide appropriate and meaningful learning outcomes. But if chosen well, they can provide another mode of learning or revision for the learner. There are numerous options, from games and quizzes to videos and animations.

'Socrative' is an excellent app for formative assessment and learners usually enjoy using it. You can create online multiple-choice style quizzes that give instant feedback to you, the teacher, so that you can quickly identify problem areas. Correction and explanation can then be dealt with immediately.

### 4.3.3 Podcasts

These audio teaching aids are a handy alternative tool, which are especially useful while learners are travelling to and from school or do not want to disturb others. Listening to the same podcasts over and over again can be especially useful for the second language learner. You can create your own podcasts online for free at 'Podbean', for example. Creating your own podcasts allows you to choose the emphasis you want and use the language you have been specifically using with your learners.

### 4.3.4 Video

Nowadays, video is not just something that learners sit down and watch in order to add variation to a lesson. Videos can be stopped periodically and questions asked in the traditional way or more recently they can easily be edited and teacher questions inserted/embedded within the video itself. This makes the process much more active which increases learning potential. You could make your own or have a look at the many examples on YouTube.

## 4.4 Providing feedback on learner work

It is necessary to provide meaningful feedback to your learners in order for them to improve the quality of their written answers and understanding of a subject. The learner may find the subject itself challenging and/or may not have the skills in English to deal fully with the question. Either way, meaningful feedback and reflection time are the answer. Providing feedback can be done in several ways, such as:

- Provide feedback orally in class so that learners write down the extra information they would need to get full marks.
- Allow learners individually to find the other pieces of information to get full marks.
- Provide a situation where the learners are actively engaged in reviewing the questions in pairs or groups with your guidance. In this way they can collectively understand what information and language would have gained full marks. You can point out command words used in the question and encourage the learners to develop an understanding of what each word means.

The last suggestion however, takes time and it could be set as a group exercise to be started in learners' own study time.

Technology is available to allow you to easily record units of your own teaching in short, manageable portions. These can be made available to learners who can watch them as a homework assignment. This saves time and allows you to concentrate on other aspects of learning and allows more time for formal assessment. The fact that these videos can be watched again and again is especially useful to the second language learner.

## 4.5 The mock/practice examination

The mock/practice examination is an important benchmark for teachers and learners, and it serves several purposes:

- It is an opportunity for the learners to be tested on the complete course material\* under proper exam conditions.
- It encourages learners to start revising for the exams earlier (otherwise they might put off revision until only a month or less before for the real exam).
- It allows learners to become more familiar with the process of being examined, so that on the day of the actual examination they might feel less stressed and more confident – this is especially important for learners who are apprehensive or nervous about taking exams.
- It provides an opportunity to spread the revision load of the subject over several months.

*\* even if learners have not completed the course by the time of the mock exams, an exam should be created which allows the learner to get the mock exam experience on the majority of the syllabus content.*

After reviewing the results of the mock exam, learners may gain an insight into the following:

- how successful their revision techniques had been
- which topics and sub-topics need more revision
- if they had enough time to complete the exam and check through their answers
- if they were able to perform properly under pressure
- whether there are questions in which they would have gained the mark(s) had their English been clearer
- if they lost marks because of not being clear and/or using the correct terminology.

If learners treat the mock exams as if they were the finals, evidence indicates that they may well perform even better in their final assessment. Some may take considerable persuasion to take the mock exams seriously enough to revise properly. They need to be encouraged to appreciate that the process is a positive and supportive one, and one in which very useful feedback will be provided.

## 4.6 Use of past examination papers

It is commonly known by learners everywhere, that working through large quantities of past papers is a major factor in their success in the final assessment. It cannot be argued that they are a very useful tool, in that, they allow learners to practice the type of question that may come up in their final exams.

It should be borne in mind that mark schemes contain several alternative acceptable answers. However, when teachers review past paper questions used in unit tests and the mock examination, they should encourage learners to suggest which is the best possible answer, and, in discussion, talk broadly around the topic area on which the question is based from the syllabus.

Learners should be aware of any data provided in the syllabus and importantly any changes to this data that might affect how they understand any practice questions you may have drawn from past papers.

The Principal Examiners Reports for Teachers (PERTs) are very helpful to use in conjunction with mark schemes. They indicate specific areas of the syllabus where learners performed well or need to improve. Some of these areas of weakness are mentioned year after year which might help you decide on the length of time you should spend on certain areas or how you arrange the order of your teaching.

Learners need to be reminded that:

- In multiple-mark questions, they would be well advised to:
  - underline key words and what exactly the question requires them to do. Answers often appear as if the learner has not noticed that there are 5 marks available for example
  - take note of the number of marks available as this will indicate the extent of the answer required
  - sometimes, in questions involving calculations, credit is given for showing working. At all times it is good practice to show every step of a calculation, even if doing so appears unnecessary to able learners in particular who arrive at the final answer easily. Learners often don't realise that 'method marks' may be awarded even if though their final answer is incorrect.
- Some questions may span several pages. A good idea would be for the learner to collect and jot down essential information near the questions themselves, which can then be neatly crossed out at the end of the exam. Doing this can prevent loss of marks through errors that are easily avoidable.
- Questions involving comparing two or more pieces of data: so often it is unclear which piece of data the learner is discussing and the comparative language is not used properly.
- Learners should not leave questions blank but if they are running out of time they should move on and then return to any questions that they have omitted at the end if there is time.

## 4.7 Command words

It is important that learners understand the vocabulary of the assessment objectives and the 'command words' of exam questions which indicate the approach they should take to an answer, for example, comparing, evaluating or describing.

Many of these 'command words' are listed in the 'Glossary of terms used in Pakistan Studies for Paper 2' which you will find in the syllabus. While these definitions are very helpful, remember that the context of the whole question will affect the explicit meaning of the command words.

Think about the skills level required to carry out each of the commands listed in the Glossary. For example, listing and defining are less complex tasks than describing and explaining; and assessing, suggesting and justifying require learners to make connections across all aspects of their learning and to provide a balanced argument with some evaluation and justification rather than merely relying on simple recall.

You can use the *Example Candidate Responses* which contains candidate responses at different grades to help explain the meaning of the command words to learners. Showing learners good sample responses to questions using different command words can help them see how increasing levels of skill relate to the marks available. Asking questions in ascending order of skill whilst teaching a topic will encourage learners to ask themselves similar questions when they are learning alone. If they become practiced at this, they will begin to see patterns emerging where the same processes and concepts can be applied to similar scenarios even if they have not been covered in class.



---

## 5: Resources and support

---

### 5.1 Finding and evaluating resources

There are many resources to aid the teaching of Pakistan Studies. They can be found in textbooks and on the internet.

Resources from the internet and from books need to be scrutinised to see if they are of use.

### 5.2 School Support Hub

This is an excellent source of information. You need a username and password to access it and these can be obtained from your Examinations Officer.

On the School Support Hub ([www.cambridgeinternational.org/support](http://www.cambridgeinternational.org/support)), you will be able to access the syllabus and copies of past papers together with their mark schemes, examiner reports and grade thresholds, and a sample 'scheme of work' which can be downloaded and used to gain further information on the delivery of this syllabus. There is also a list of resources and a link to the 'Discussion Forum' where teachers can post comments and questions. It is worth looking at this from time to time and following interesting threads even if you do not post any comments of your own.

### 5.3 Training

The Cambridge International Events calendar ([www.cambridgeinternational.org/events](http://www.cambridgeinternational.org/events)) on our public website has a list of upcoming training events. You can also register for these courses on the site. These include:

- online self-study and tutor-led courses; the tutor-led courses are highly recommended to help you improve your teaching skills
- face-to-face courses; held at venues all over the world at different times throughout the year; these enable you to meet up with other teachers, and also to interact directly with a trainer from Cambridge.

In addition, Cambridge International runs professional development courses for teachers who want to develop their thinking and practice. These include a range of Cambridge International Certificate and Diploma level programmes in:

- Teaching and Learning
- Educational Leadership
- Teaching Bilingual Learners
- Teaching with Digital Technologies

You can find information about these at [www.cambridgeinternational.org/qualifications/teacher](http://www.cambridgeinternational.org/qualifications/teacher).

## Appendix: Sample lesson plan template

<b>Lesson:</b>		<b>School:</b>	
<b>Date:</b>		<b>Teacher name:</b>	
<b>Class:</b>	<b>Number present:</b>	<b>Number absent:</b>	
<b>Learning objectives to which this lesson is contributing</b>			
<b>Lesson objectives</b>			
<b>Vocabulary, terminology and phrases</b>			
<b>Previous learning</b>			
<b>Plan</b>			
<b>Planned timings</b>	<b>Planned activities</b>	<b>Resources</b>	
Beginning			
Middle			
End			
<b>Additional information</b>			
<b>Differentiation: How do you plan to give more support? How do you plan to challenge the more able learners?</b>	<b>Assessment: How are you planning to check learners' learning?</b>	<b>Health and safety check: ICT links</b>	

Reflection and evaluation	
<b>Reflection</b> Were the lesson objectives realistic? What did the learners learn today? What was the learning atmosphere like? Did my planned differentiation work well? Did I stick to timings? What changes did I make from my plan and why?	<b>Use the space below to reflect on your lesson. Answer the most relevant questions from the box on the left about your lesson.</b>
Summary evaluation	
<b>What two things went really well? (Consider both teaching and learning.)</b> 1. 2.	
<b>What two things would have improved the lesson? (Consider both teaching and learning.)</b> 1. 2.	
<b>What have I learned from this lesson about the class or individuals that will inform my next lesson?</b>	

Cambridge Assessment International Education  
The Triangle Building, Shaftesbury Road, Cambridge, CB2 8EA, United Kingdom  
t: +44 1223 553554  
e: [info@cambridgeinternational.org](mailto:info@cambridgeinternational.org) [www.cambridgeinternational.org](http://www.cambridgeinternational.org)

Copyright © UCLES May 2019 (updated Nov 2021)